

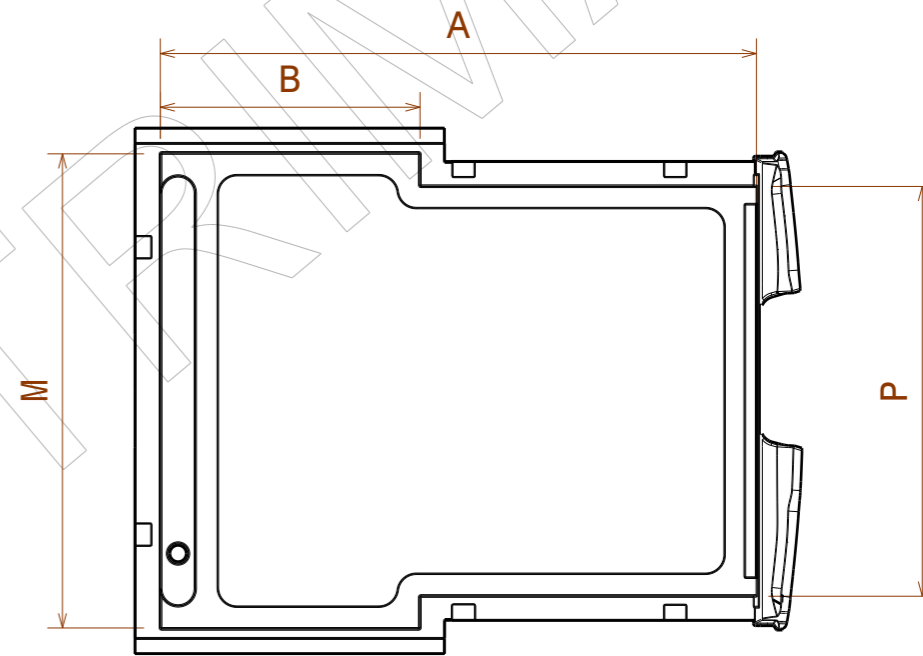

VEHICLE BASE	B9 3 SEATS
WHEELBASE	2728
OVERALL LENGTH	4380
CARGO VOLUME (m ³)	1,87
FLOOR LENGTH (A)	1570
LENGTH BEFORE WHEEL ARCH (B)	680
SIDE-DOOR WIDTH (BOTTOM) (C)	505
SIDE-DOOR WIDTH (TOP) (D)	450
SIDE-DOOR WIDTH (MIDDLE) (E)	350
SIDE-DOOR ENTRY HEIGHT (F)	870
SIDE-DOOR SILL HEIGHT (G)	660
REAR SILL HEIGHT (H)	640
REAR DOOR ENTRY HEIGHT (I)	970
INTERIOR HEIGHT (J)	1005
BREAK-POINT HEIGHT (K)	620
WIDTH BETWEEN WHEEL ARCHES (L)	1080
FRONT FLOOR WIDTH (M)	1255
WHEEL ARCH HEIGHT (N)	357
INSIDE ROOF WIDTH (O)	1060
REAR-DOOR ENTRY WIDTH (P)	1080



This plan is the exclusive property of TRIMAT and must not be reproduced or disclosed without written permission

Established by Jonathan FERAY	Date : 04/11/2013	Scale :	Mass :	CONFIDENTIAL	
		Program ECO-KIT	Name B9 CARGO AREA DIMENSIONS		
		Boulevard Jean Monnet ZI du pré Avrin 49360 MAULEVRIER Tel : 02 41 64 04 66 Fax : 02 41 64 98 30		Design number EKI0001 / EKI0003	Revision 3D 